

EonStor® B12F 1U RAID Series

High performance density and flexible scalability for 4Gbps FC SAN

- B12F-R1430
- B12F-G1430
- B12F-G1431



OVERVIEW

The B12F RAID series is the first 1U-profile RAID system using the latest 2.5" enterprise-class disk drives. The 2.5" drives enable the design of a highly compact RAID enclosure with better transaction rates than its 3.5" counterpart.

Use of 2.5" drives delivers greater performance density, takes up to 66% less of rack space, and consumes almost only one third less of power.

The B12F RAID subsystems support SAS/SATA HDDs and SATA SSDs. They can also be expanded for larger capacity by attaching to 1U JBOD for 2.5-inch SAS and SATA drives or 2U, 3U JBOD for 3.5-inch SATA drives.



for 2.5-inch SFF HDD or SSD !

THE SCALABILITY

Tiered Storage:

Mixing SSD and HDD (SAS or SATA) in 1U, 2U or 3U JBOD



SAS HDD
or
SATA SSD



SATA
HDD

60 HDD in just **5U** space !



HIGH AVAILABILITY

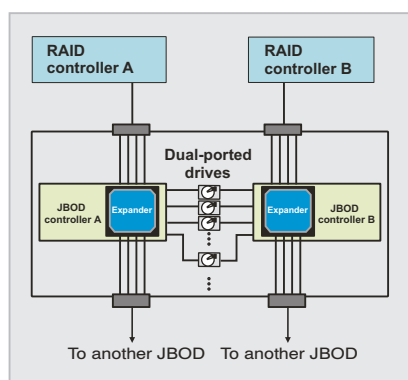

Utilizing drives' dual-ported connectivity, data paths are routed through redundant expanders and controller modules to ensure the optimal availability of your data.

In addition to path redundancy, all components are designed to withstand harsh environments and strenuous workloads. With the help of intelligent firmware algorithms, the enclosure can be operated with an ease of mind.

HIGHLIGHTS

- 4Gbps FC to SAS/SATA
- High availability dual-active RAID controllers and fault-tolerant hardware
- Host interface: 4Gbps Fibre Channel
- Drive interface: 3Gbps 2.5" disk drives
- Max. scalability: redundant-controller: 1 RAID + 3 JBOD
single-controller: 1 RAID + 4 JBOD
- 5th generation, ASIC400 architecture:
 - Hardware RAID5 + RAID6 engine
 - Dedicated, 18Gbps sync. cache channels
- EonPath Multi-pathing software
- Feature-rich SANWatch management suite
- RAID and JBOD matching table:

Model	1U JBOD (SAS/SATA)	2U JBOD (SATA)	3U JBOD (SATA)	Configuration
B12F-R1430	B12S-J1000-R	S12S-J1002-R	S16S-J1000-R	Dual-controller; fault-tolerant paths
B12F-G1430/1431	B12S-J1000-S	S12S-J1000-G	S16S-J1000-S	Single-controller; single path

Connections to the 2U S12S-J1000-G and the 3U JBODs require the SFF-8088 to SFF-8470 cables.

AVAILABLE MODELS

Models	Controller	Host Ports	Channels	Drive Bays	Expansion Port	Scalability
B12F-R1430	Redundant	4 (SFP)	4 (4Gbps FC)	12	2 (SAS)	1 RAID + 3 JBOD
B12F-G1430/G1431	Single	2 (SFP)	2 (4Gbps FC)	12	1 (SAS)	1 RAID + 4 JBOD

SPECIFICATIONS

Subsystem Characteristics

- RISC CPU
- ASIC400 RAID engine
- Up to 2GB cache per controller
- 4G FC host ports
- LCD keypad panel
- BBU (per controller)
- Optional for B12F-G1430/1431
- Default DDR cache memory (per controller)
- 10/100 Ethernet port (per controller)
- COM ports (per controller)
- PSUs
- Cooling modules
- Diagnostic LEDs on all FRUs

Drive Interface

- No. of disk trays
- 3Gbps SAS/SATA HDD and SATA SSD
- Drive-side enclosure service
- SAS multi-lane expansion port (per controller)

Host Connection Ports

- Data single path bandwidth
- Tag command queuing

RAID Configurations

- RAID levels 0, 1(0+1), 3, 5, 6, 10, 30, 50, 60
- Up to 32 logical drives (varied by memory size)
- Up to 1024 LUNs (varied by memory size)
- Multiple array configurations
- Background rebuild/scan/initialization
- Infortrend Smart fault management technologies

High Availability

- Redundant, hot-swappable FRUs
- Subsystem self-diagnostics
- Li-Ion battery backup
- UPS status detection
- Cluster ready

Management Software

- Java-based SANWatch software
- Web-based embedded RAIDWatch
- Terminal via RS-232C
- Telnet/SSH
- LCD keypad panel
- Event notification methods:
Email/Fax/LAN broadcast/SNMP traps/SMS/MSN

OS Support

- Microsoft Windows Server 2003/2008
- Sun Solaris
- Red Hat Linux
- SuSE Linux
- Asianux
- MAC OSX
- HP-UX
- * Windows WHQL-Windows Server 2003

Approvals

- BSMI, CB, CE, FCC, UL, cUL, GOST-R

RoHS Compliance

Requirements

B12F-R/G1430

- AC Input: 115-230VAC 380W with PFC
- DC Output: 12V-24A; 5V-30A

B12F-G1431

- AC Input: 100-240VAC 250W with PFC
- DC Output: 12V-16A; 5V-25A

Relative Humidity

- 5% to 95% non-condensing
- Operating Temperature:
0°C to 40°C (without BBU)
0°C to 35°C (with BBU)

Dimensions

- With chassis ears/protrusions:
483mm W x 43.5mm H x 500.6mm D
(19 x 1.71 x 19.7 inches)
- Without chassis ears/protrusions:
444.8mm W x 43.5mm H x 497.8mm D
(17.5 x 1.71 x 19.6 inches)

© 2009 Infortrend Technology, Inc. All rights reserved.

· Any information provided herein is without warranties of any kind of and is subject to change without prior notice.
· Infortrend, SANWatch and EonPath are registered trademarks of Infortrend Technology, Inc.

· Infortrend logo and ESVA are trademarks of Infortrend Technology, Inc.
· All other names, brands, or services are trademarks or registered trademarks of their respective owners.



Asia Pacific
Infortrend Technology, Inc.

Tel: +886-2-2226-0126
E-mail: sales.ap@infortrend.com
e-Support: support.ap@infortrend.com

Americas
Infortrend Corporation

Tel: +1-408-988-5088
E-mail: sales.us@infortrend.com
e-Support: support.us@infortrend.com

Europe (EMEA)
Infortrend Europe Ltd.

Tel: +44-1256-707-700
E-mail: sales.eu@infortrend.com
e-Support: support.eu@infortrend.com

Germany
Infortrend Deutschland GmbH

Tel: +49(0)894515187-0
E-mail: sales.de@infortrend.com
e-Support: support.eu@infortrend.com

China
Infortrend Technology, Ltd.

Tel: +86-10-63106168
E-mail: sales.cn@infortrend.com
e-Support: support.cn@infortrend.com

Japan
Infortrend Japan, Inc.

Tel: +81-3-5730-6551
E-mail: sales.jp@infortrend.com
e-Support: support.jp@infortrend.com